

# RC

Konik Çevirme  
Conical Rounder



**STANDART ÖZELLİKLER:**  
STANDART FEATURES:

- Alüminyum döküm konik ve kollar
- Cast aluminium cone and tracks
- Paslanmaz şase ve kapaklar
- Stainless steel chasis and body cover
- Yavaş ilk kalkış
- Soft start
- Otomatik unluk
- Automatic flour duster
- Kolay hareket etmesini sağlayan tekerlekler
- Mobile with wheels

**SEÇENEKLER:**  
OPTIONS:

- Hız kontrolü
- Speed control
- Sıcak hava üfleme
- Hot air blowing

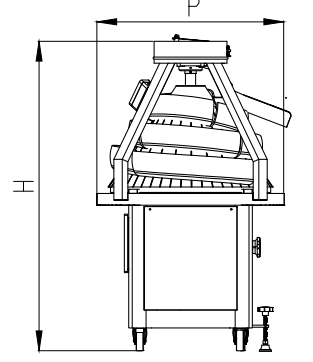
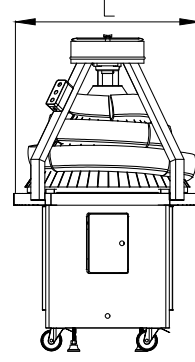
**TEKNİK ÖZELLİKLER**

## TECHNICAL SPECIFICATION

	RC-S	RC-L	RC-XL	RC-A
GRAMAJ AĞIRLIĞI / DOUGH GRAMMAGE RANGE	50-250	120-600	250-900	250-1000
YUVARLAMA KOLLARI MEKANİZMA TÜRÜ TRACKS TYPE	Sabit/Fixed	Sabit/Fixed	Sabit/Fixed	Ayarlanabilir/Adjustable
YUVARLAMA MESAFESİ / ROUNDING LENGTH	550 cm	550 cm	650 cm	380 cm
HAMUR BANT ÇIKIŞ YÜKSEKLİĞİ DOUGH OUTPUT HEIGHT	95 cm			
MAX. YUVARLAMA KAPASİTESİ MAX. ROUNDING CAPACITY	2400 pcs/h			
DIŞ ÖLÇÜLER (LxPxH) EXTERNAL DIMENSIONS (LxPxH)	95x95x160 cm	95x95x160 cm	100x100x160 cm	95x95x160 cm
KONTROL PANELİ / CONTROL SYSTEM	Elektromekanik / Electromechanic			
ELEKTRİK GÜCÜ / ELECTRICAL POWER	0,55 kw			
ELEKTRİK BAĞLANTI TÜRÜ ELECTRICAL CONNECTION	380 V 50 Hz N+PE 3Phase			
AĞIRLIK / WEIGHT	200 kg			